

# ESDEC

INNOVATIVE MOUNTING SYSTEMS

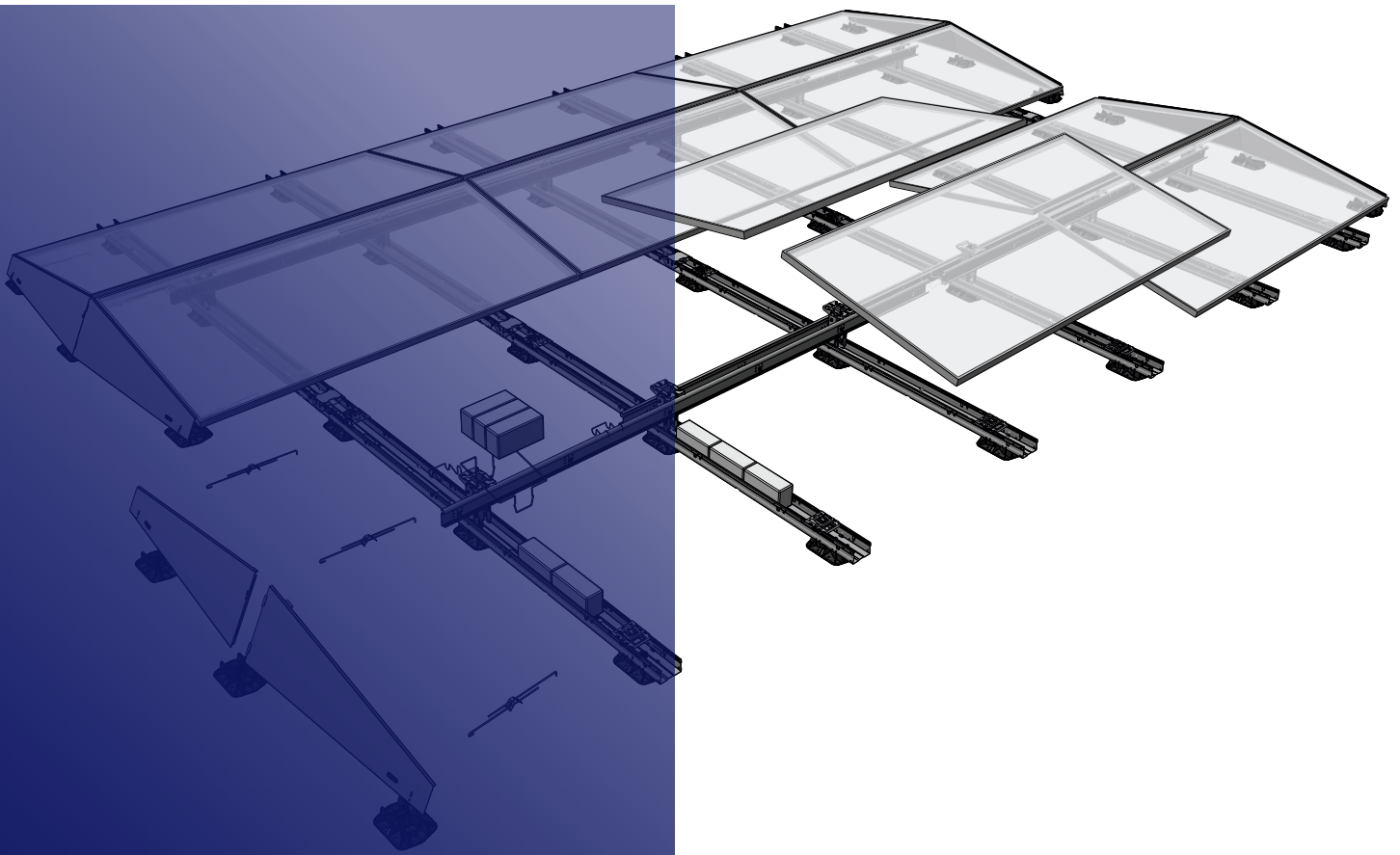

## MANUAL FLATFIX WAVE PLUS

**FLATFIX**

WAVE  
PLUS

REV02

[www.esdec.com](http://www.esdec.com)

## DISCLAIMER

This assembly manual must be kept in a safe place for future use!

For the duration and conditions of the warranty, we recommend that you contact your supplier. We refer to our General Terms and Conditions of Sale and Delivery, which are available on request. The manufacturer rejects all liability for any damage or injury resulting from failure to follow this assembly manual carefully and observe the usual precautions during transport, assembly and using the FlatFix Wave assembly system.

## GENERAL INSTALLATION CONDITIONS

### General

Failure to comply with the instructions in this document may result in the lapse of all warranty and product liability claims. The data, comments and opinions contained in this document are binding and should be checked for completeness and up to date status. Esdec BV reserves the right to change this document without notice.

### Stability and condition of the roof

The roof must be in good condition and strong enough to support the weight of the solar panels including additional materials, wind and snow loads. Check the stability of the roof and adjust the roof/structure if necessary, if in doubt, call in a structural engineer. Ensure that the load threshold of the roof is not exceeded, either locally or as a whole.

### Safety warnings

- The installation of the FlatFix Wave assembly system must be carried out as standard by qualified technical personnel (at least 2 skilled persons).
- The addition or omission of parts may adversely affect the operation and is strongly discouraged!
- Before installing the solar panels, the roof must be clean, dry, flat and free of algae, etc.
- Avoid assembly in strong winds and on a wet and slippery roof surface.
- Always work on the roof with fall protection and, if necessary, with safety nets and edge protection.
- Wear shoes with a reinforced tip and firm non-slip soles.
- Always wear suitable protective clothing when performing work.
- When moving the material (solar panels, etc.) always use a hoisting aid/hoisting installation.
- Always place a ladder on a strong, stable surface.
- Always place the ladder at an angle of about 75° and allow it to protrude about 1 metre above the roof edge.
- If possible, secure the ladder at the top with a rope or tension strap.
- Preferably work according to the manual "Safe Working on Roofs".
- **NB:** In the assembly of the standard unit and the start unit, make sure that hands and/or fingers are not trapped in the area of the hinged parts!

### Range of application of FlatFix Wave

- Suitable for all wind zones, terrain categories and building heights, provided the maximum wind pressure does not exceed the maximum panel specification.
- For roof heights above 12m please contact your supplier.
- Roof material: Concrete, Bitumen, EPDM, PVC, TPO. For other roof coverings, please contact your supplier.
- Roof slope: Up to 5° counts as a flat roof. If your roof slope is > 5°, please contact your supplier.
- Maximum field size: 40 x 40m.
- For panels with a panel width between 990mm and 1070mm the DR1 modules should be used.
- For panels with a panel width between 1070mm and 1150mm the DR2 modules should be used.
- In all cases, the panel frame must meet the specification as shown on the next page.

Due to continuous improvement efforts, the product may differ in detail from what is described in this manual. This means that the instructions given are only intended as a guide for the installation of the product mentioned in this manual.

This manual has been compiled with the greatest possible care, but the manufacturer cannot accept liability for any errors in this manual or their consequences. In addition, all rights are reserved and no part of this manual may be reproduced in any form whatsoever.

### Edge area

The distance from the solar panels to the edge of the roof must be approximately 1/5 of the height of the building with a minimum distance of 30 cm, due to the very turbulent wind currents in this area. No solar panels must be installed in this area, either in whole or in part. The edge area to be maintained is derived from the FlatFix Wave calculator.

### Ballast

If your roof is higher than 12 metres, we recommend that you consult your supplier to help you determine the correct ballast.

### Standards, regulations and rules

When installing the assembly system, it is important to follow the assembly manual and related standards to prevent accidents.

In particular, observe the following standards, regulations and rules:

- Buildings Decree 2012 (regulations for the construction, use and demolition of buildings)
- NEN 7250:2014 - Structural aspects of solar energy systems
- NEN-EN 1990 - Basis of structural design
- NEN-EN 1991-1-3 - General loads - snow load
- NEN-EN 1991-1-4 - General loads - wind pressure
- NEN 1010:2015 - Electrical installations for low voltage (HD-IEC 60364)
- NEN-EN-IEC 62305 - Lightning protection
- Workplace safety laws and regulations - safe working and working conditions
- NEN 3140 - safe operation of low-voltage installations
- VCA checklist - Safe working on the work floor
- Scaffolding directive & workplace safety A-sheet ladders/scaffolding

### Removal and disassembly

Dispose of the product in accordance with local laws and regulations. At the end of the service life, all materials are recyclable. The plastic roof supports are attached to the units and the wind deflectors by means of a click system.

### Warranty

Warranty according to the Esdec BV warranty terms. These can be found on the website [www.esdec.com](http://www.esdec.com)

### Liability

The manufacturer accepts no liability for damage or injury caused by failure to comply (strictly) with the safety guidelines and instructions in this manual, or by negligence during installation of the product and the accessories listed in this document.

- Typing errors reserved



# 1 BILL OF MATERIALS

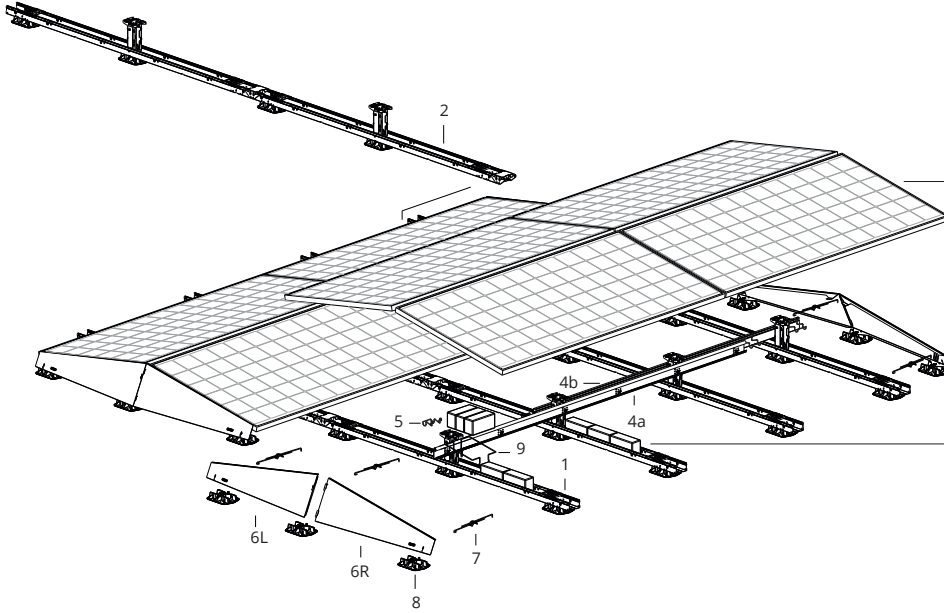

## PANEL FRAME

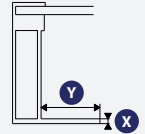

	min	max
X	1,2 mm	2 mm
Y	14 mm	35 mm

## BALLAST

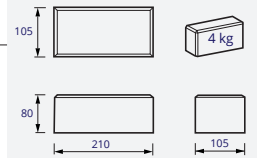

## UNITS

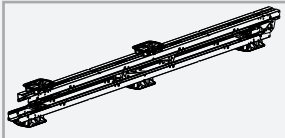

- 1a. FlatFix Wave Dual Start unit 4P DR1  
1009101
- 1b. FlatFix Wave Dual Start unit 4P DR2  
1009151

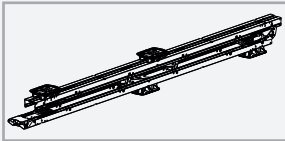

- 2a. FlatFix Wave Dual Unit 4P DR1  
1009100
- 2b. FlatFix Wave Dual Unit 4P DR2  
1009150

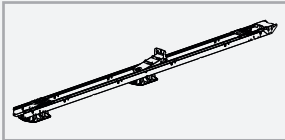

- 3a. FlatFix Wave Dual Unit 2P DR1  
1009102
- 3b. FlatFix Wave Dual Unit 2P DR2  
1009152

DR1 (Dual range 1): panel widths 990mm to 1070mm  
DR2 (Dual range 2): panel widths 1070mm to 1150mm

## WIND DEFLECTORS

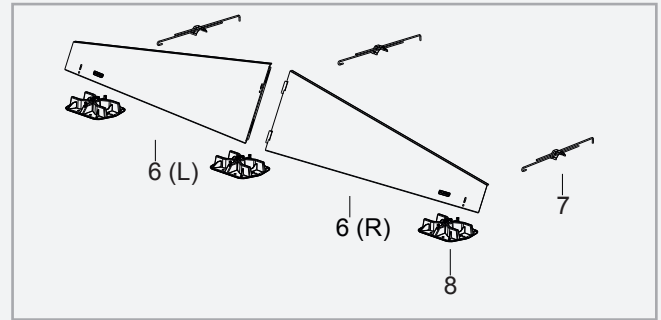

6. FlatFix Wave Winddeflector  
DR1 kit (= wind deflector L and R)  
1009103

7. FlatFix Wave Connector pin (set of 3)  
1009122

8. FlatFix Wave Roof support  
1009120

## STABILIZERS

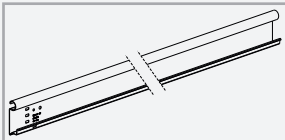

- 4a. FlatFix Wave Stabilizer 2900  
1009110
- 4b. FlatFix Wave Stabilizer 3530  
1009111
- 4c. FlatFix Wave Stabilizer 4000  
1009114
- 4d. FlatFix Wave Stabilizer 4350  
1009115

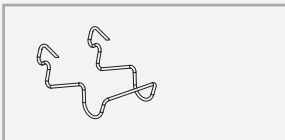

5. FlatFix Wave Cable bracket  
1009124

## ACCESSORIES

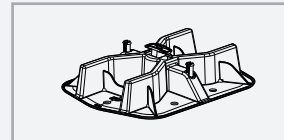

8. FlatFix Wave Roof support  
1009120

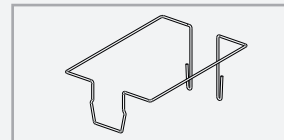

9. FlatFix Wave Ballast bracket  
1009123

## TOOLS & EQUIPMENT

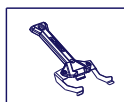
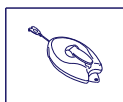
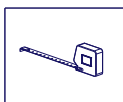
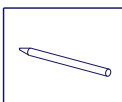

## 2 PREPARATIONS FOR ASSEMBLY

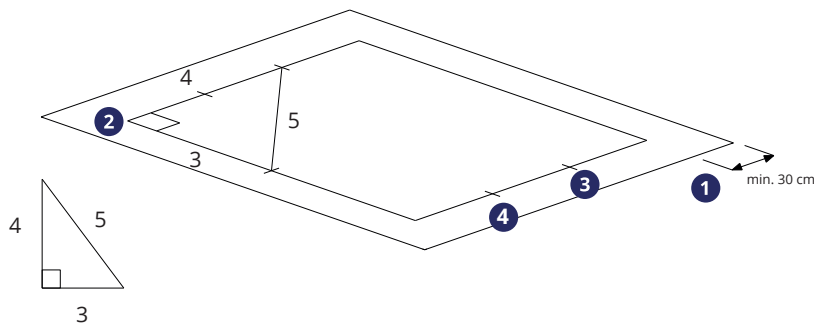
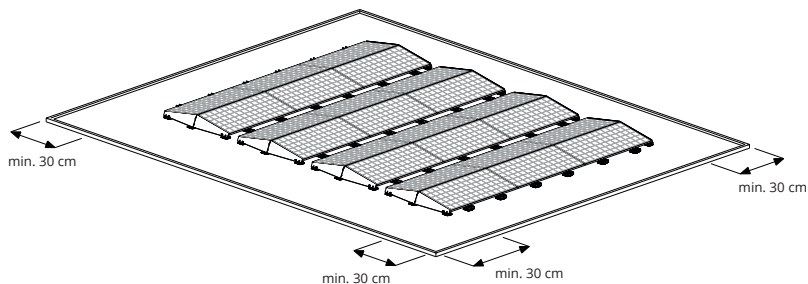

### 1 PREPARING THE ROOF AND ALIGNING (THE FIELDS)



- ⚠ **NB:** Make sure your roof is in good condition! If in doubt, consult your roof specialist.
- ⚠ **NB:** Follow the installation drawing and make sure the fields are well coordinated.

### 2 MEASURING AND MARKING (OF FIELD)

Calculate how much space you need based on the dimensions of your panel.

1. Keep at least 30 cm around the panel field free.
2. Draw field contours at right angles with 3-4-5 rule. Use a chalk or blemish cord for this. Also mark each panel with a short stripe.
3. Mark the panel edges.
4. Mark with chalk the place on the roof where the start units are to be placed.

- ⚠ **NB:** The distance from the solar panels to the edge of the roof should be approximately 1/5 of the height of the building. See the installation drawing that is calculated with the Esdec calculator for the correct distance.

**Tip:** Check the measurement using the 3-4-5 rule.

## 3 PLACE DUAL START UNIT

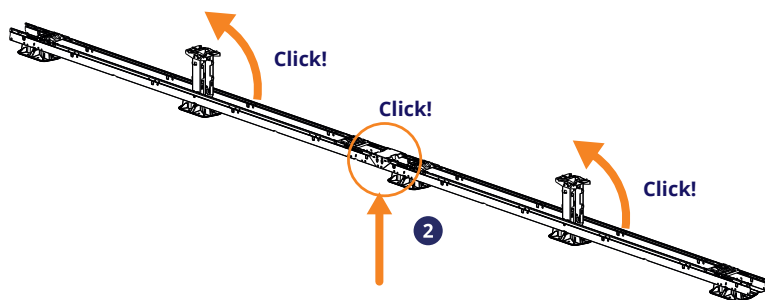
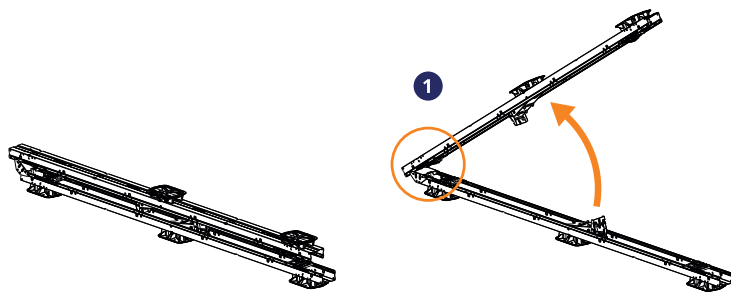

### 1 PLACE THE DUAL START UNIT DIRECTLY ON THE RIGHT PLACE ON THE ROOF

### 2 UNFOLD THE TOP OF THE DUAL START UNIT UNTIL IT IS COMPLETELY FLAT AND CLICKS INTO PLACE

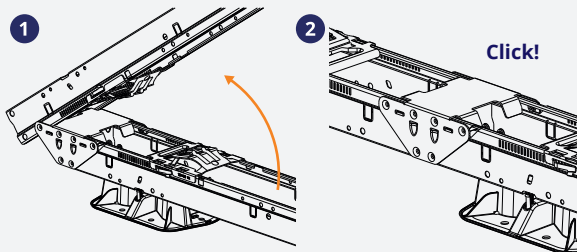

**Tip:** Lift the dual start unit slightly at the coupling, by its own weight the unit clicks firmly into place.

- ⚠ **NB:** Make sure that your hands/fingers are not trapped in the area of the hinged parts!

### 3 PLACE THE HIGH BASE (2x) IN STANDING POSITION SO THAT IT CLICKS

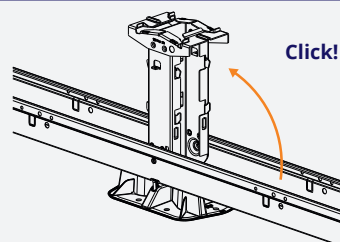

See Annex A for an explanation of how to attach additional roof supports to the unit.

## 4 POSITIONING THE DUAL START UNITS

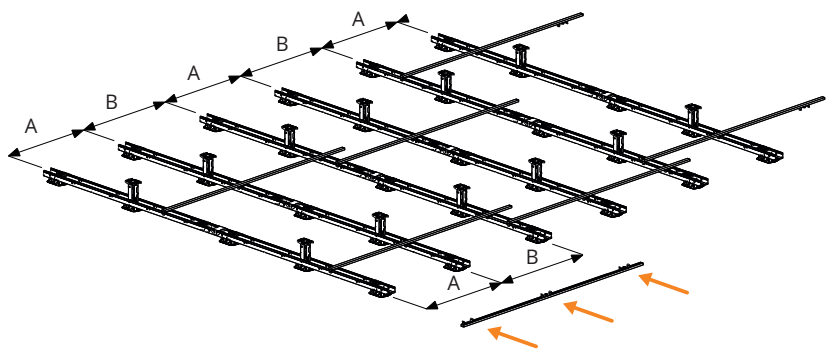
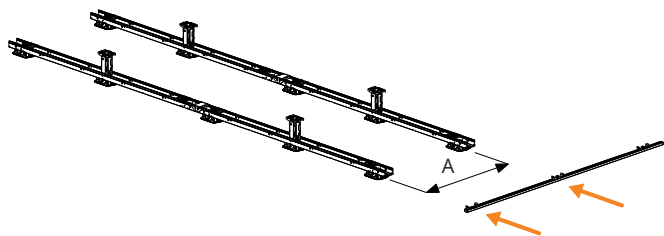
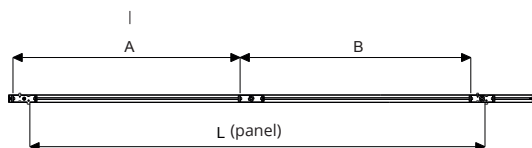
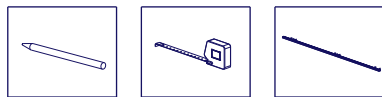

### 1 POSITION THE 2nd DUAL START UNIT

See Annex B for an explanation of the use of the Measuring bar.

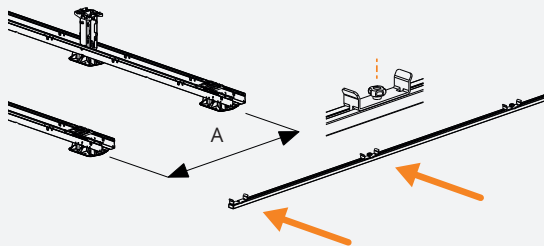

Place the first dual start unit at the edge of the panel field, with a centre-to-centre distance (A). To do this, use the measuring bar at various places on the dual start unit.

### 2 POSITIONING OF THE OTHER DUAL START UNITS

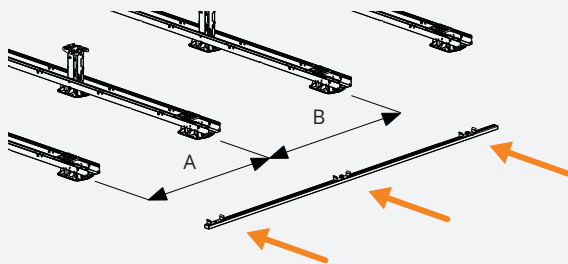

Make sure that the dual start units are aligned with each other.

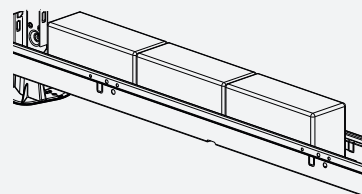

**Tip:** Ballast the aligned units to prevent them from shifting.

## 1 PREPARE COUPLING

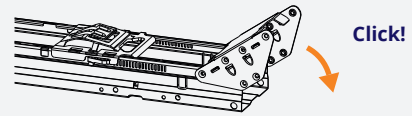

Press the coupling down until it clicks.

## 2 COUPLE DUAL UNITS TO THE DUAL START UNITS

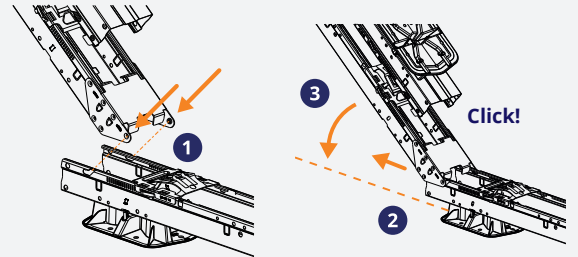

1. Slide the lugs of the dual unit coupling into slots of the dual start unit at an angle of 45 degrees.
2. Pull back the cams so that the coupling is firmly engaged.
3. Carefully turn the dual unit downwards until it is completely flat and clicks into place.

## 3 OPEN THE TOP OF THE DUAL UNIT UNTIL IT IS COMPLETELY FLAT AND CLICKS INTO PLACE

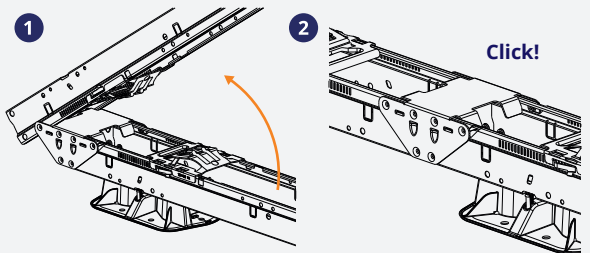

**Tip:** Lift the dual unit slightly at the coupling, by its own weight the unit clicks firmly into place.

**⚠ NB:** Make sure that your hands/fingers are not trapped in the area of the hinged parts!

## 4 PLACE THE HIGH BASE (2x) IN STANDING POSITION SO THAT IT CLICKS

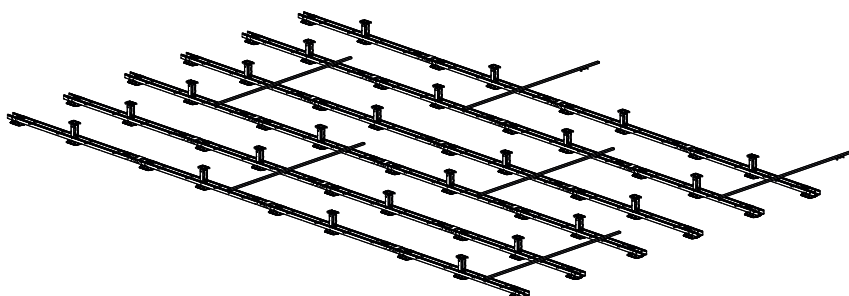
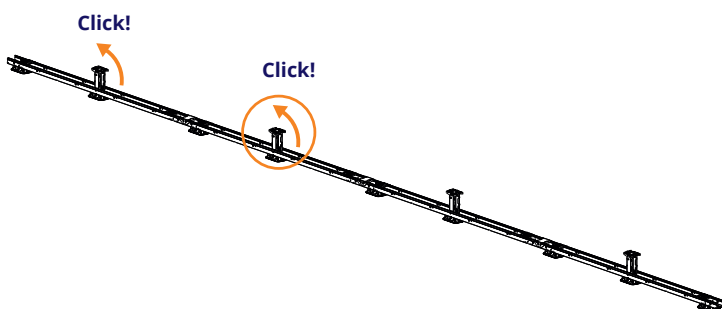
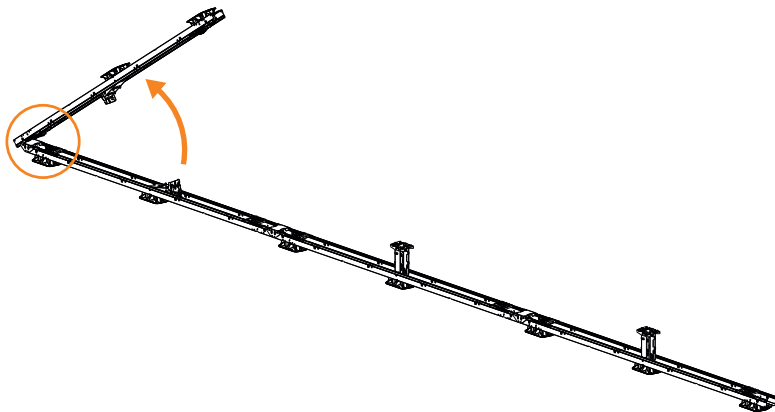
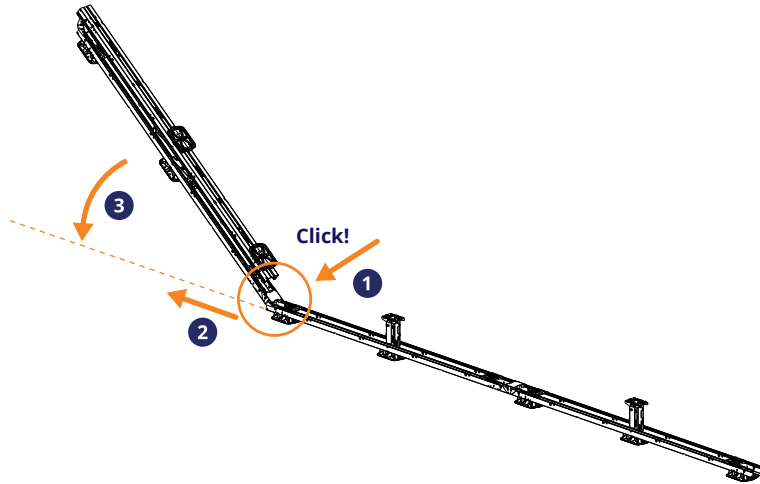
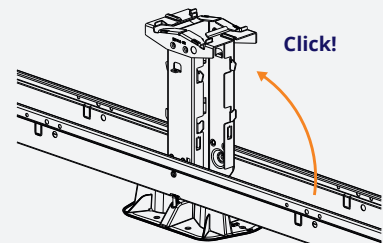

## 6 ASSEMBLY OF STABILIZERS AND CABLE BRACKETS

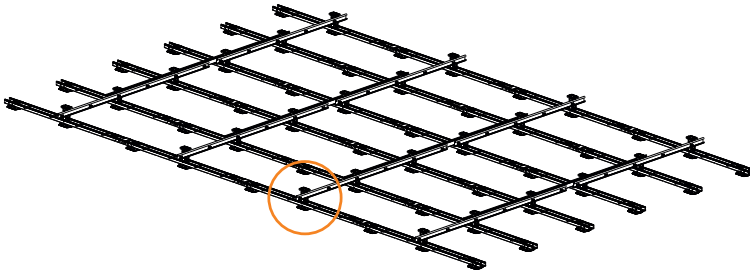

### 1 POSITIONING STABILIZERS IN CONNECTION

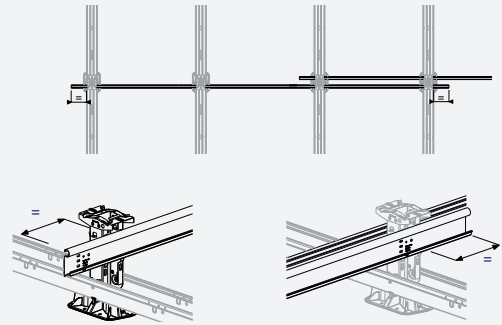

**⚠ NB:** Follow the installation drawing for the positions of the stabilizers. Place the stabilizer in the centre aligned with 4 high base elements whose ends protrude an equal distance.

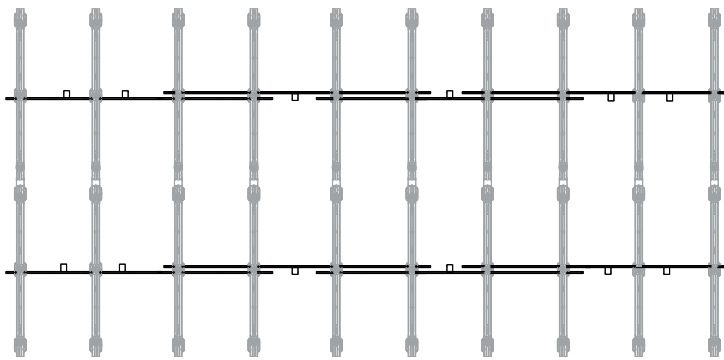

### 2 ASSEMBLE STABILIZERS ON HIGH BASE

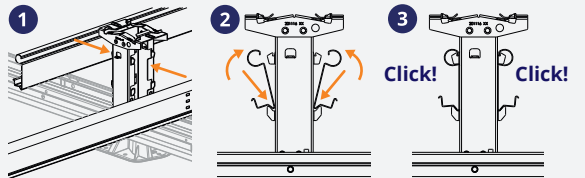

Place the stabilizers at an angle to the edge of the high base and turn them back to the base until they click.

**Tip:** Click on 2 stabilizers (front & back) at the same time for easier assembly.

**⚠ NB:** Align the first stabilizer well and then align the other stabilizers.

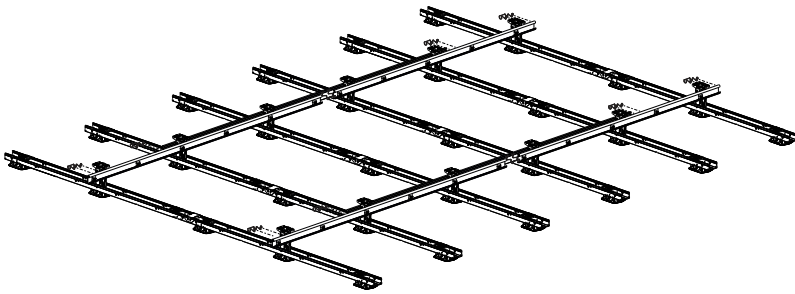

### 3 ASSEMBLE CABLE BRACKETS ON STABILIZERS

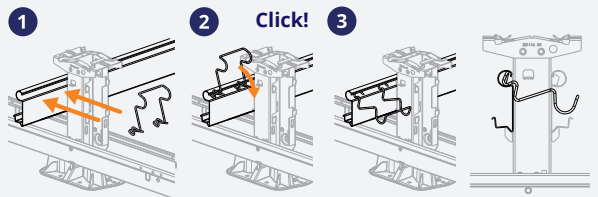

Place the 2 ends of the cable rack in the recess of the stabiliser and rotate the cable rack 90 degrees downwards.

**⚠ NB:** Place the cable brackets in the space between 2 stabilizers. See Annex C for further specifications.

**⚠ NB:** Make sure that the cable brackets face the back of the stabilizer.

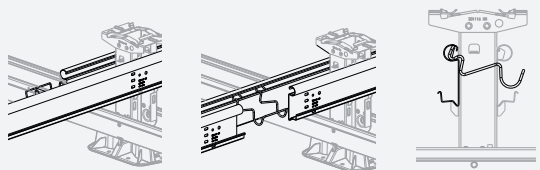



## 7 PLACING THE BALLAST

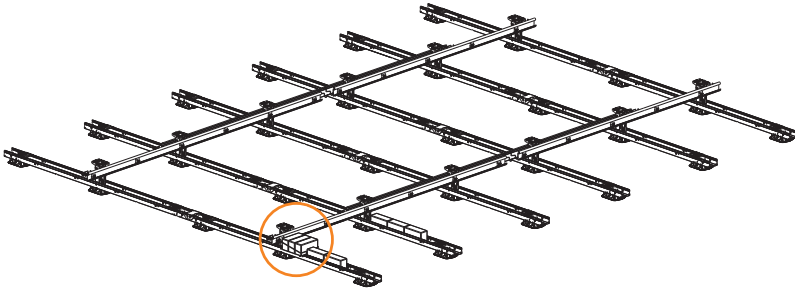

### 1 PLACING THE BALLAST (GENERAL)

**⚠ NB:** The installation drawing is the guideline for the ballast positions. Using the calculator, the ballast positions are determined. Place the ballast at the points indicated by the calculator.

### 2 PLACE STANDARD BALLAST (3x4 kg.)

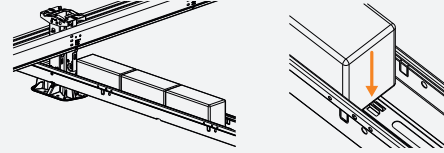

Place the standard ballast (3x4 kg.) in the units on the high base. Place 1st ballast stone against the ridge.

### 3 PLACE OPTIONAL BALLAST (5x4 kg.)

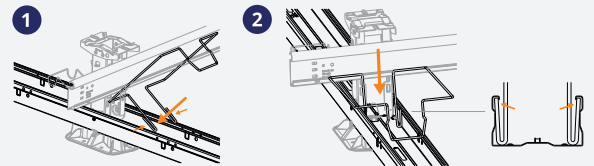

1  
Tilt the ballast bracket at an angle in the unit on the high base.

2  
Tilt the ballast bracket back into the module.

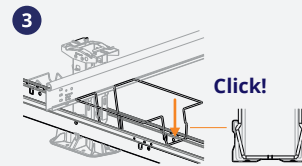

3  
Slide the bracket against the high base and then click the bracket into the long edge!

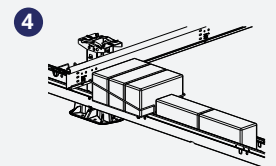

4  
Place the ballast (3x4 kg.) in the ballast track and the other ballast (2x4 kg.) in the module.

### 4 PLACE THE BALLAST IN POSITION ON THE BALLAST BRACKET AT THE POSITION OF A STABILIZER

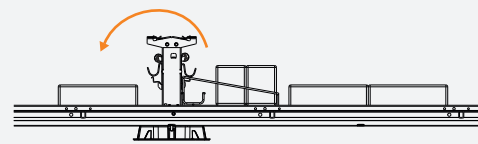

**⚠ NB:** If there is a wire tray, there is only room for 2 stones, instead of 3 stones, in the ballast area. Then place this 3rd stone in the unit on the other side of the high base.

## 8 ASSEMBLY OF SOLAR PANELS AND CABLES

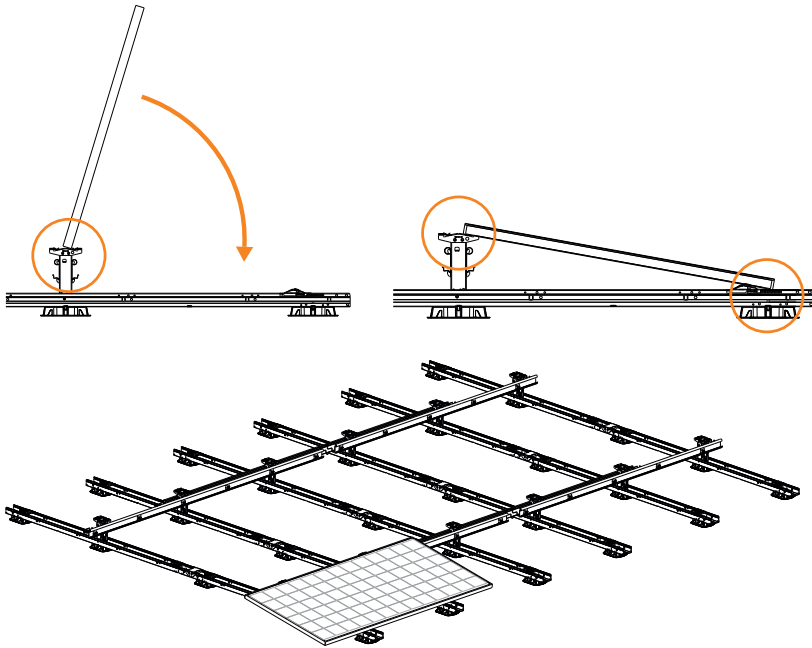

### 1 POSITION AND CLAMP THE SOLAR PANEL ON THE HIGH BASE ELEMENTS

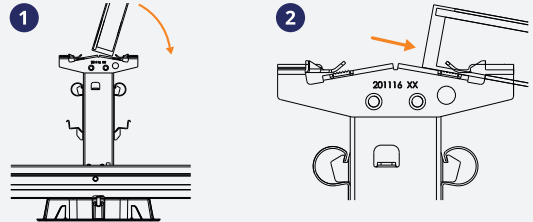

1. Place the first solar panel on 2 high base elements. Make sure the panel is properly centred. Tilt the panel so that the lower edge of the panel is flush with the high base elements.
2. Slide the panel edge under the clips of the high base elements as far as it will go.

### 2 CLAMP THE SOLAR PANEL ON THE FRONT SIDE

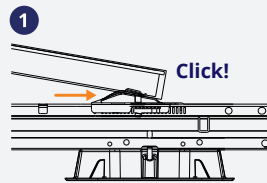

1. Slide the clips of 2 panel locks over the edge of the front panel until the panel is firmly clamped in place.

### 3 PLACING CABLES OR MC4 CONNECTOR

1. Place the cables or MC4 connector of the solar panel in the gutter of the stabilizers at the place of the high base elements.
2. Insert the cables or the MC4 connector into the cable supports.
3. Connect the cables or MC4 connector to the stabilizers using cable ties.

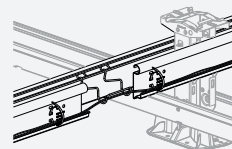
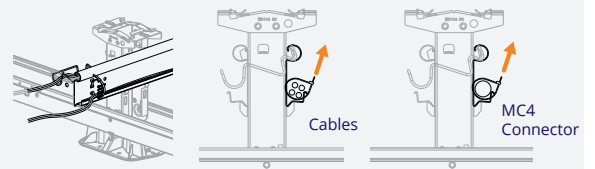

4. Connect the connectors of the cables of the first and second solar panel to each other.
5. Assemble the second solar panel.
6. Repeat the steps to complete the rows.

See Annex C for an explanation of cable management.

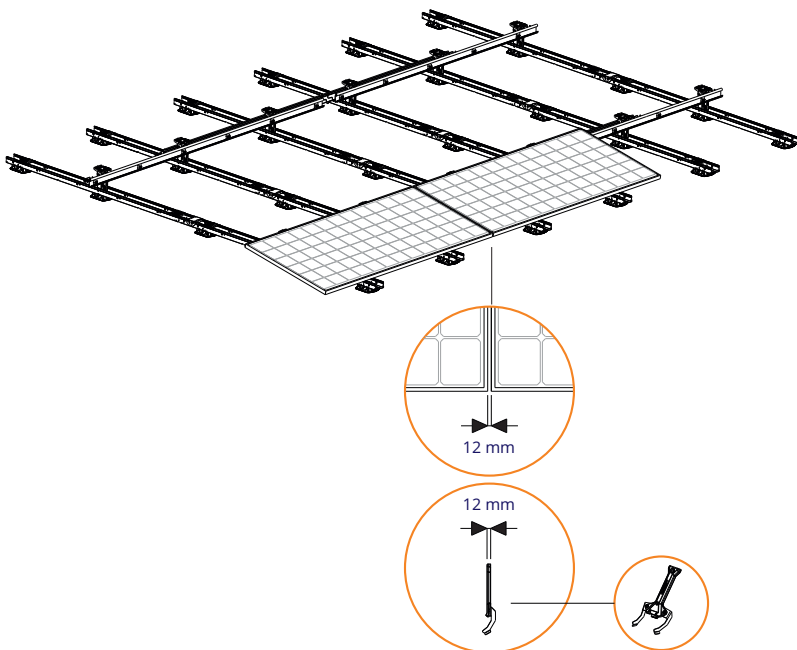

## 9 ASSEMBLE WIND DEFLECTOR L TO THE FIELD

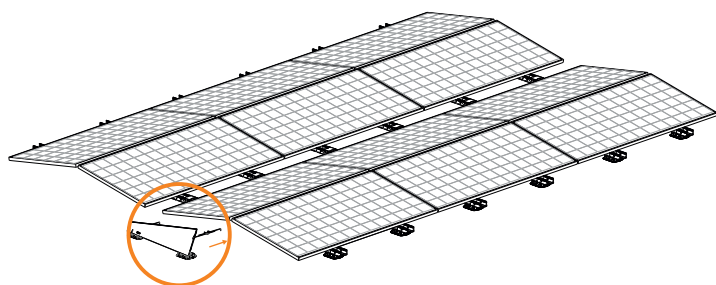
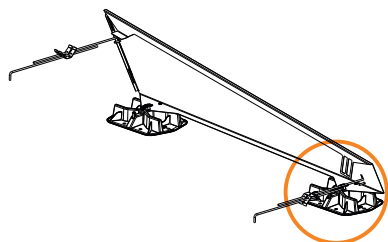
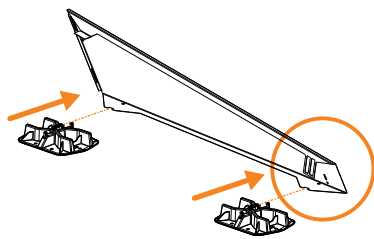
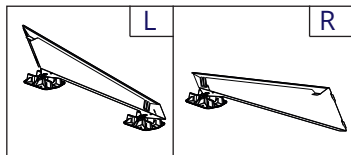

### 1 ASSEMBLE THE ROOF SUPPORTS UNDER WIND DEFLECTOR L

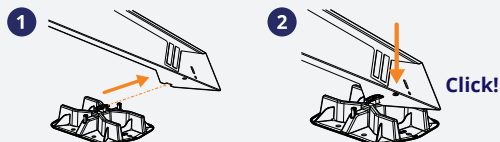

1. Slide the roof supports over the flange of wind deflector L.
2. Click the wind deflector on the roof supports.

### 2 ASSEMBLE 2 CONNECTOR PINS TO WIND DEFLECTOR L

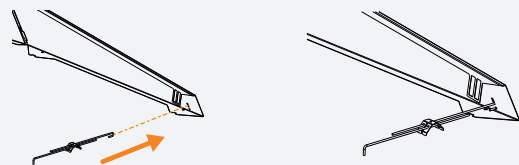

### 3 ASSEMBLE WIND DEFLECTOR A ON THE UNIT WITH CONNECTOR PINS

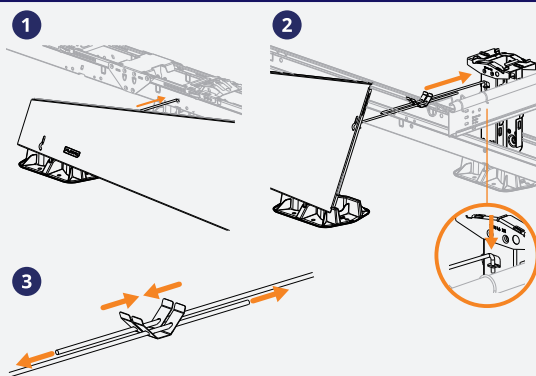

1. Hook the outer connector pin into the hole of the unit.
2. Hook the middle fastening pin into the hole of the high base.
3. Squeeze the springs to shorten the connector pin.

### 4 DR1: SLIDE WIND DEFLECTOR L AGAINST THE PANEL FRAME AND BEND THE FLANGE UNDER THE FRAME

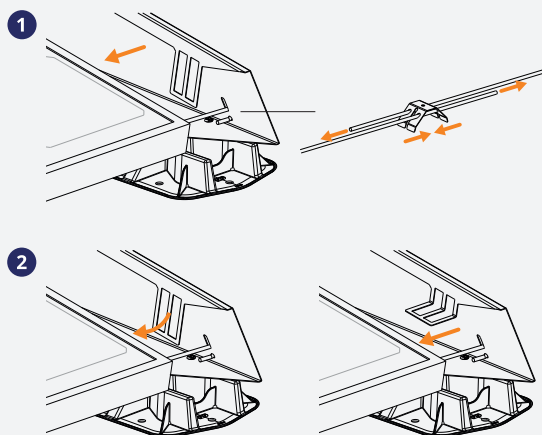

1. Slide wind deflector L against the panel frame on the side of the field by inserting the connector pin.
2. Bend the flanges under the panel frame by hand.
3. Make sure wind deflector L is properly connected to the panel frame.

**⚠ NB:** The wind deflector is universal, depending on the panel size, the panel may protrude relative to the wind deflector.

## 10 ASSEMBLE WIND DEFLECTOR R ON THE FIELD

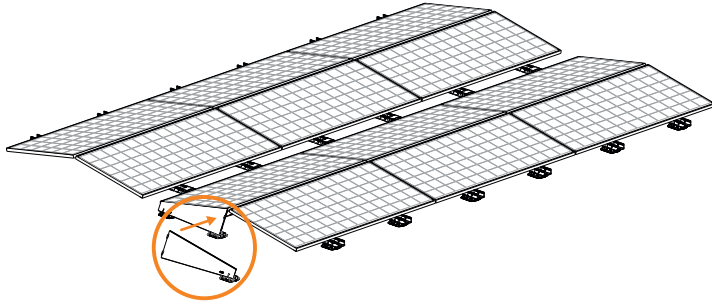
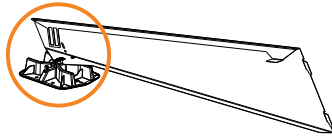

### 1 ASSEMBLE THE ROOF SUPPORT UNDER WIND DEFLECTOR R

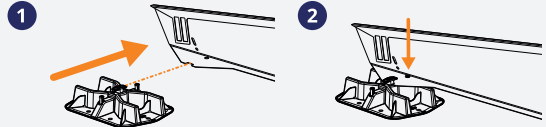

1. Slide the roof support over the flange of wind deflector R.
2. Click the wind deflector on the roof support.

### 2 CONNECT WIND DEFLECTOR R TO WIND DEFLECTOR L

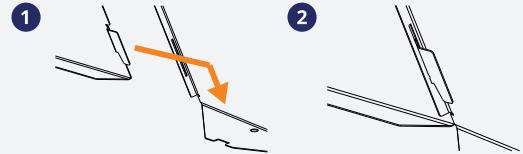

### 3 DR1: ASSEMBLE WIND DEFLECTOR R ON THE FIELD

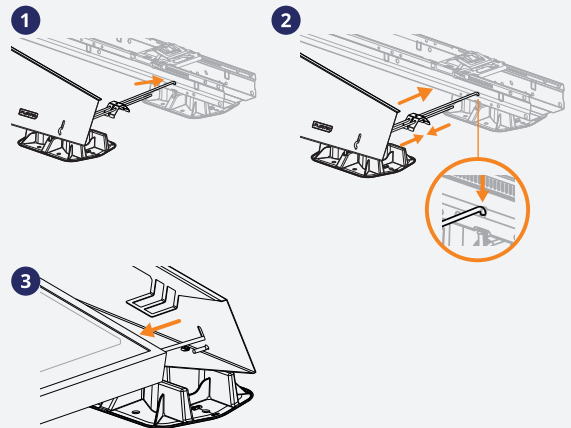

1. Hook the fastening pin into the hole of the unit.
2. Slide wind deflector R against the field by inserting the connector pin.
3. Bend the flanges under the panel frame by hand.
4. Make sure wind deflector R fits well on the panel frame.

**⚠ NB:** The wind deflector is universal, depending on the panel size, the panel may protrude relative to the wind deflector.

### 4 ASSEMBLE THE OTHER WIND DEFLECTORS L AND R ON THE REST OF THE FIELD

Assemble the other wind deflectors L and R on the rest of the field. (Repeat the steps in Sections 9 and 10).

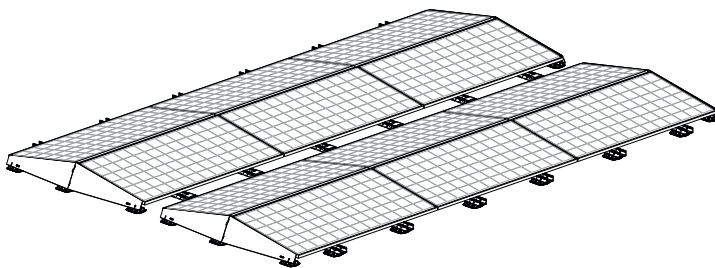

### 5 THE PANEL FIELD IS NOW READY!

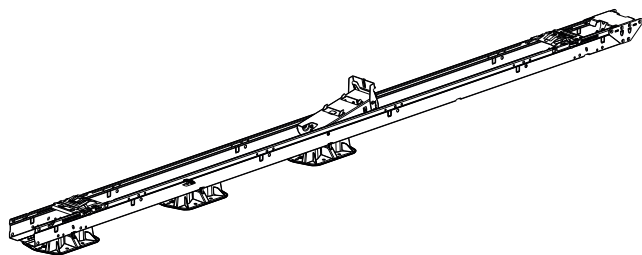
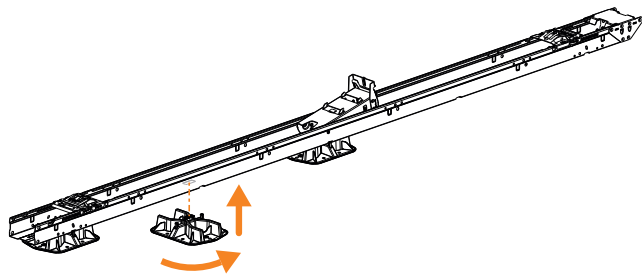

## 1 ASSEMBLE THE ADDITIONAL ROOF SUPPORT TO THE UNIT

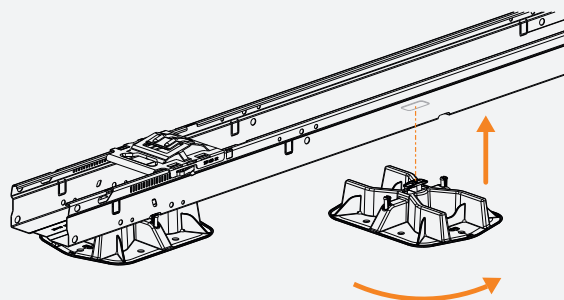

Place the roof support in the correct position underneath the unit. Place the hook of the roof support through the hole in the unit. Turn the roof support 90 degrees until it engages.

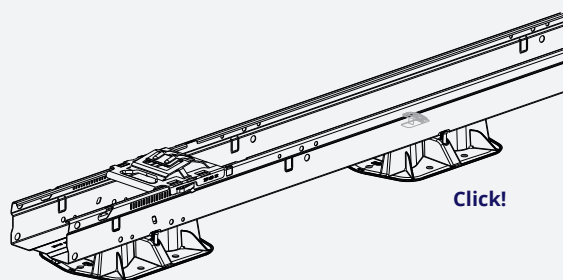



## 1 SETTING THE MEASURING BAR

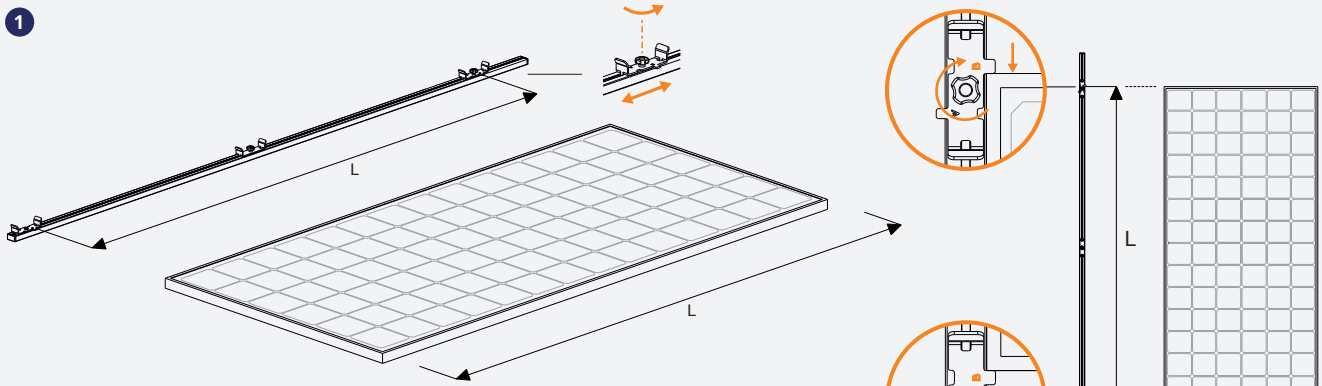

Take size L from the solar panel. Set size L on the Measuring bar (= 1st grip to 3rd grip). Use the B mark on the handle as a reference.



Set size A with a tape measure. (= 1st grip to 2nd grip). A = recommended distance between the panels

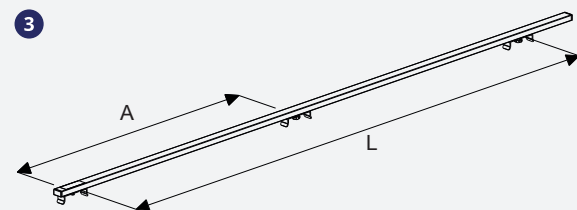

Turn the Measuring bar so that the handles face down.

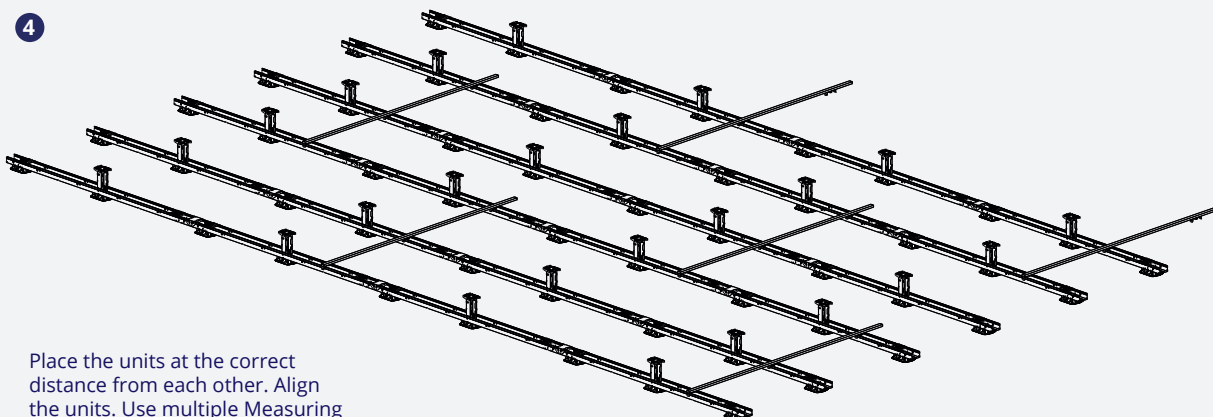

Place the units at the correct distance from each other. Align the units. Use multiple Measuring bars for this.

**1** TABLE

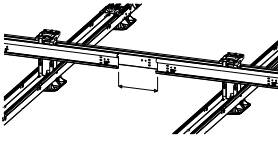
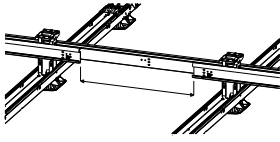
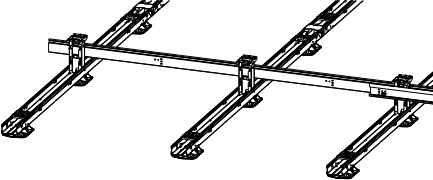
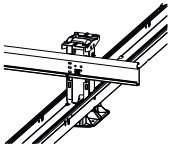
Open space $\leq$ 350mm	Open space $>$ 350mm	End of row without stabilizer	End of row with stabilizer
			
1x cable bracket	2x cable bracket	3x cable bracket	0x cable bracket
1x In the middle	2x 10cm relative to the ends	1x 10cm relative to the end 2x 5cm relative to the high base	15 metres
Cable ties	Cable ties	Cable ties	2x cable tie (detail)

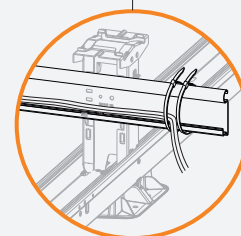

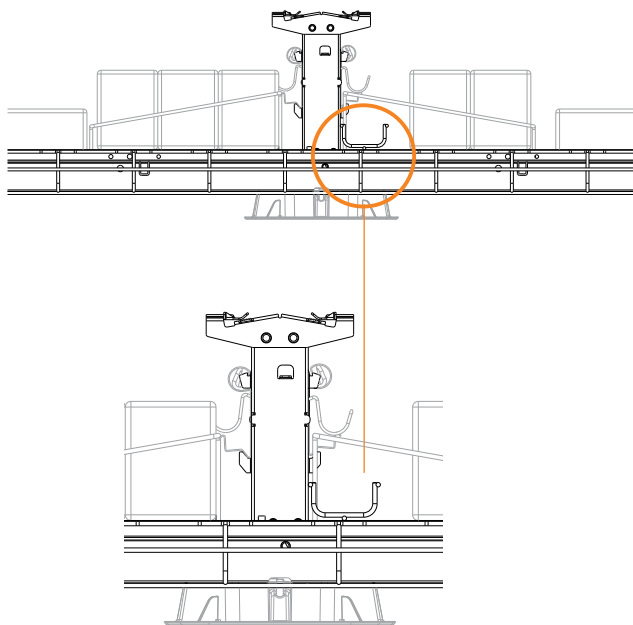
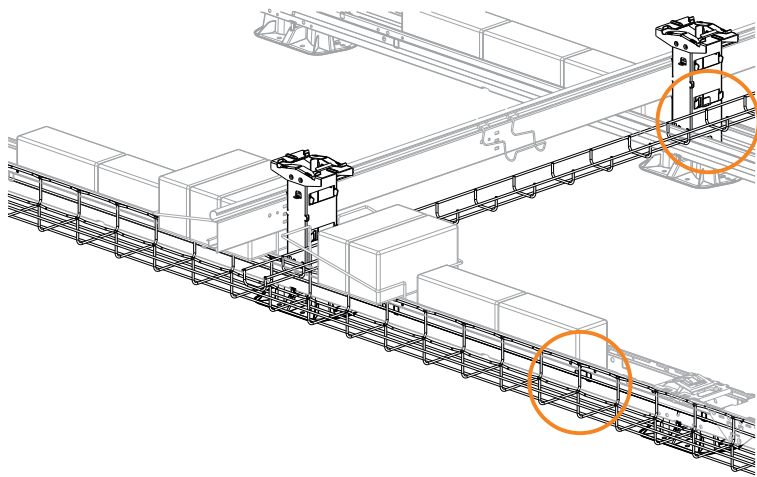

## 1 TIP: ASSEMBLE A LARGE WIRE TRAY ON THE SIDE OF THE (START) UNITS

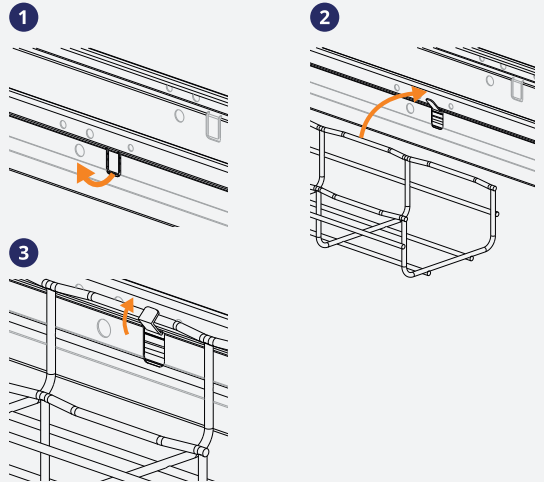

1. Fold out the lips on the side of the units.
2. Bring the top bar of the wire gutter over these lips.
3. Fold the lips further around the rod to enclose it.  
Make sure that the wire tray does not rise above the units.

## 2 TIP: ASSEMBLE A SMALL WIRE TRAY ON THE HIGH BASE ELEMENTS OVER THE (START) UNITS

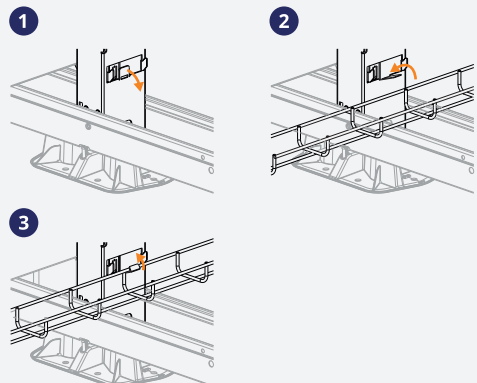

1. Fold out the lips of the high base elements.
2. Bring the top bar of the wire tray over these lips.
3. Fold the lips further around the rod to enclose it.

## 3 CONNECTORS AND CABLES TO BE FIXED IN THE STABILIZER AND ON THE CABLE SUPPORTS

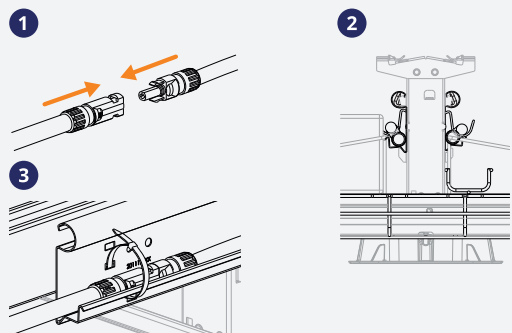
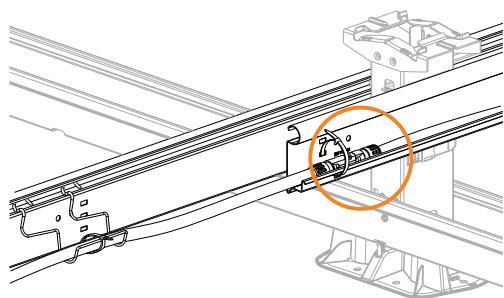

1. Connect the MC4 connectors.
2. Place the MC4 connector with the cables in the channel section of the stabilizers and in the openings in the cable supports.
3. Secure the MC4 connector and the cables with cable ties through the perforations in the stabilizers.

## 1 SELECTION DIAGRAM

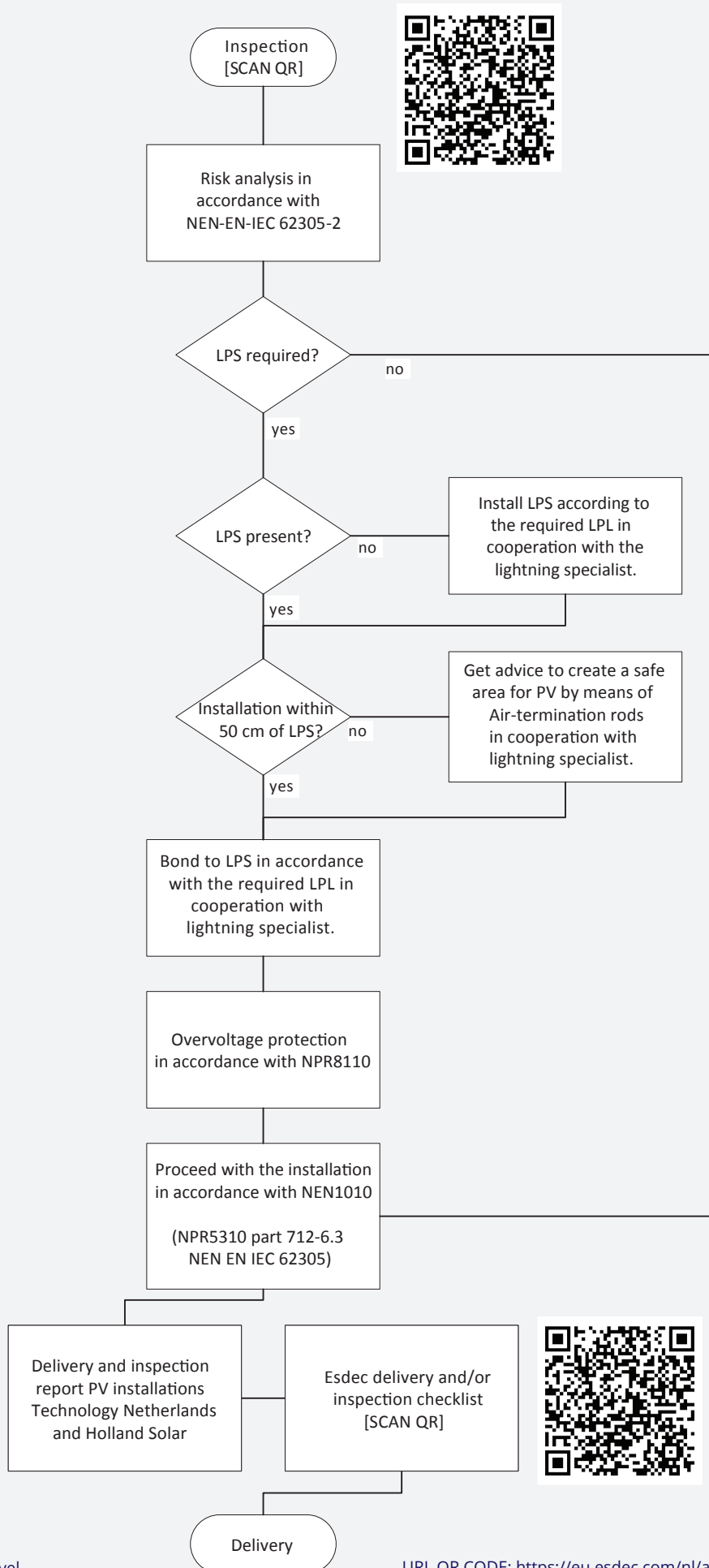

LPS = lightning installation  
LPL = lightning protection level

URL QR CODE: <https://eu.esdec.com/nl/advies-en-voorwaarden/>

## 2 METHOD OF GROUNDING/BONDING

Thanks to the integrated part bonding, no additional bonding between the metal parts is required.

1. The teeth at the top of the high base elements engage in the frame edge of the solar panels.
2. The teeth at the bottom of the high base elements engage in the module frame of the solar panel.
3. Fully tightening the panel lock ensures correct contact of the panel frame with the high base.

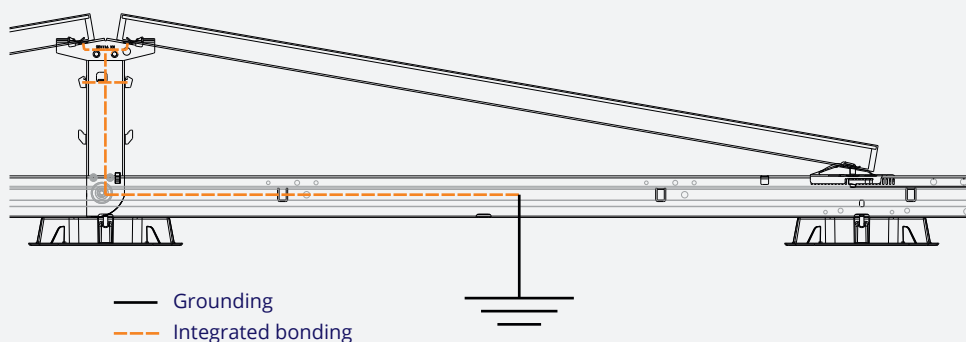
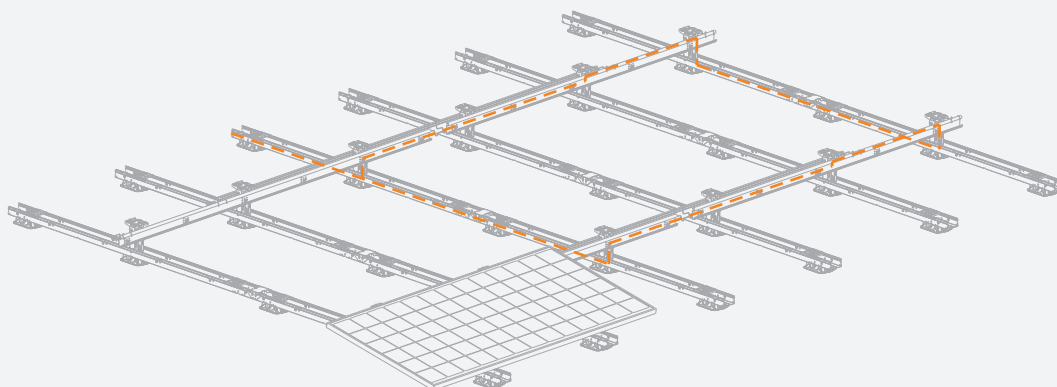
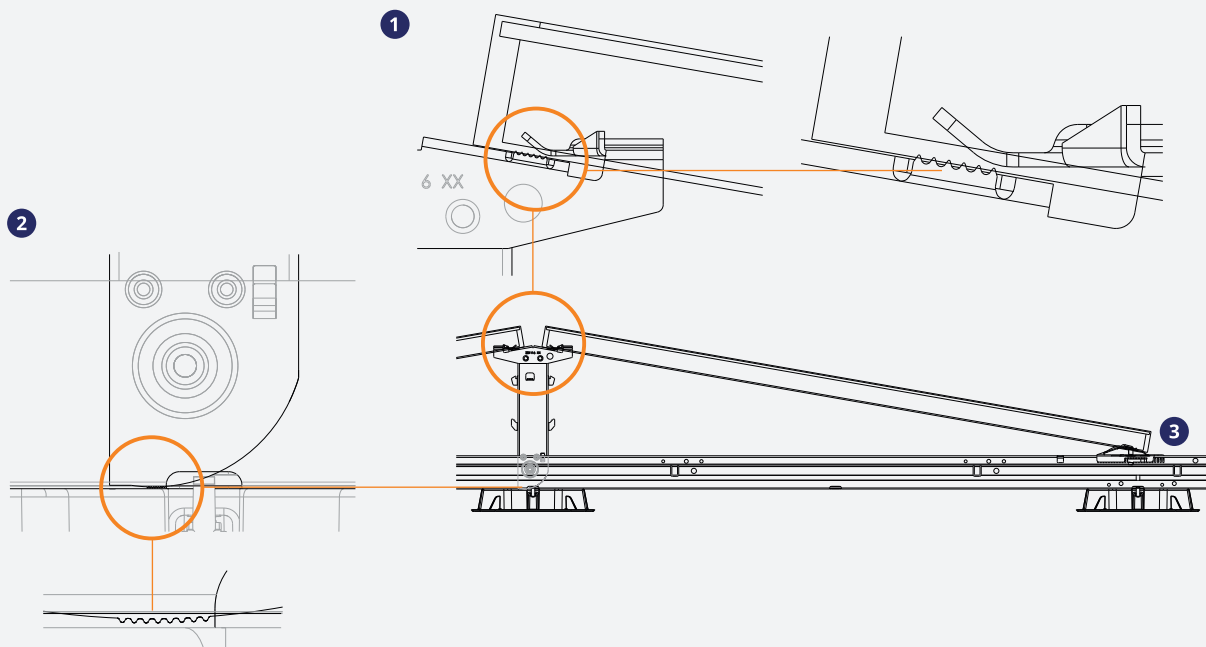

### INSTALLATION OF THE BONDING CONDUCTOR

- The grounding conductor ( $\geq \varnothing 4\text{mm}^2$ ) runs parallel to the plus and min. conductors and is connected to a separate grounding point of the inverter.
- Connect at least one rail in a field to a ground rail.
- Each individual PV field will have its own bonding conductor.
- The grounding cable can be fitted with a cable eye and screwed to the rail together with serrated spring washers.
- Correct assembly: protected against corrosion and firmly assembled.



## 3 LPS: LIGHTNING PROTECTION

Lightning protection guidelines.

**CONSULT YOUR LIGHTNING PROTECTION SPECIALIST TO ANALYSE YOUR PROJECT.**

**1 Preferred application: Isolating lightning protection system (with Air-termination rods)**

- Determine the safe separation distance (S) according to NEN-EN-IEC 62305 (at least 0.5 metres).
- Try to respect the separation distance between PV system (PV) and lightning protection system (LPS).
- This way you're able to keep PV system separated from Lightning protection system to prevent unwanted lightning current in building.

**2 If this is not possible, connect the PV system to LPS according to the applicable lightning protection level (LPL);**

- See table 1, use at least 16mm<sup>2</sup> connections.
- Check necessity additional overvoltage protection type 1 and/or type 2.
- Make sure that the cable support systems are also grounded and connected to LPS. NB: Metal cable support systems also belong to the PV system.
- Make sure that the grounding cable is routed parallel to the DC cables.

IN BOTH CASES: CONSULT YOUR LIGHTNING PROTECTION SPECIALIST IN ADVANCE TO ANALYSE YOUR PROJECT AND TO PREVENT ANY UNWANTED SAFETY ISSUES. ESDEC IS IN NO CASE RESPONSIBLE FOR THE APPLICATION AND/OR COMBINATION WITH THE LIGHTNING PROTECTION SYSTEM AT THE ROOF. USE THE EXPERTISE OF YOUR SPECIALIST AND MAKE SURE A SAFE INSTALLATION CAN BE GUARENTEED ACCORDING - NEN-EN-IEC 62305 - NEN1010 (NPR5310 – deel 712 par. 6.3)

table 1

Mesh size	LPL level	PV System connect every..
5x5 metres	I	5 metres
10x10 metres	II	10 metres
15x15 metres	III	15 metres
20x20 metres	IV	20 metres

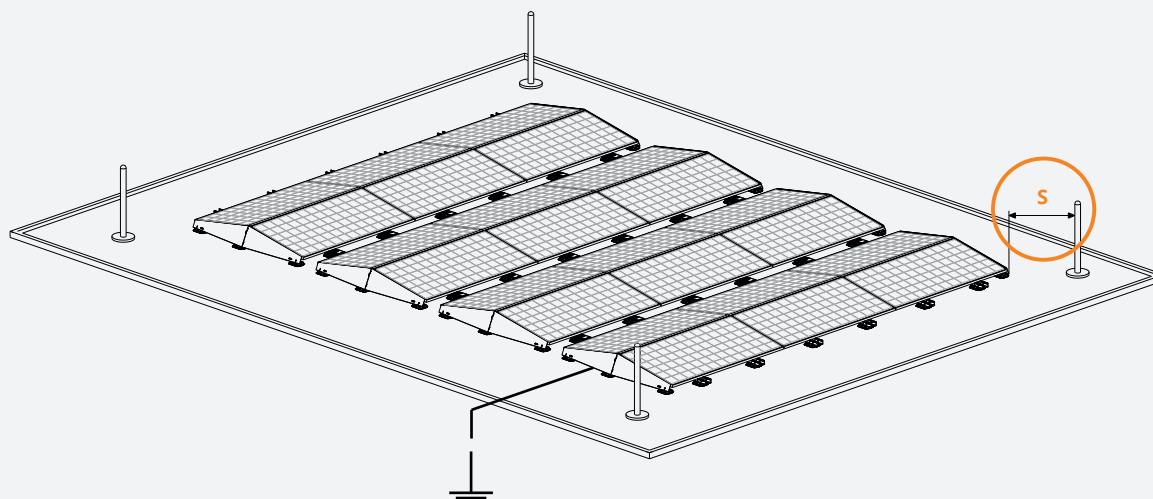

LPS = lightning installation  
LPL = lightning protection level

## 1 DISASSEMBLE THE PANELS

1

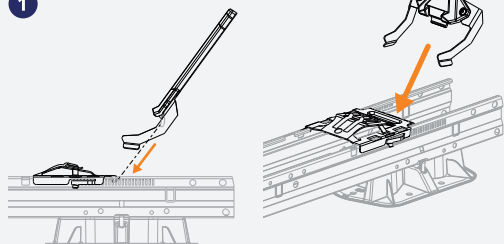

1. Place the unlocking tool on the locking lever.

2

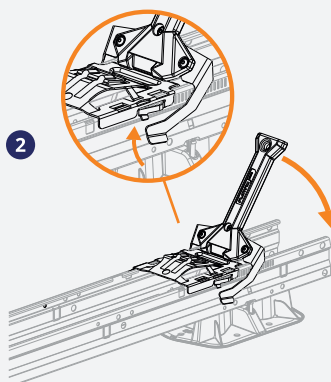

2. Carefully turn the unlocking tool downwards so that the panel latch can be slid back.

3

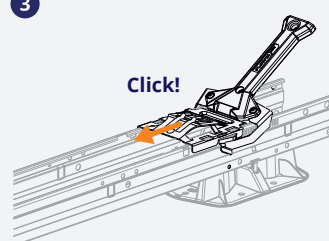

3. Slide the panel all the way back in the direction of the panel. This unlocks the low side of the panel.

4

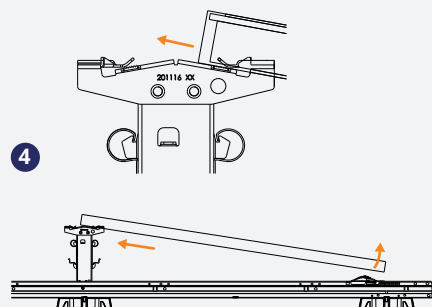

4. Lift the panel a few cm and push the panel backwards out of the high base elements.

5



5. Now you can lift the whole panel.

**QUICK**  
**RELIABLE**  
**INNOVATIVE**

19-07-2021

## MAKE THE CLICK WITH ESDEC

Esdec has been developing, producing and supplying professional roof-assembly systems for solar panels since 2004. ClickFit and FlatFix are inspired by the installer who regularly installs solar panels. Easy, quick, reliable installation using innovative, high-quality, durable assembly systems: Esdec makes it possible.

### Esdec

Londenstraat 16  
7418 EE Deventer  
Netherlands

☎ +31 850 702 000  
✉ [info@esdec.com](mailto:info@esdec.com)

[www.esdec.com](http://www.esdec.com)